

# **KNOTS AND LASHINGS**

# CONTENTS

The Development of Rope,	3
Making Rope,	4
Whipping,	6
Caring for Rope,	7
Bight, Loop, Overhand,	7
End Knots,	9
Knots for Joining,	10
Tying Ropes to Objects,	13
Knots for Loops,	19
Other Useful Knots,	22
Splices,	27
Lashings,	30
Index,	34
Credits,	36
About the E-book Edition,	37
About the E-book Editor,	37

## THE DEVELOPMENT OF ROPE

Fastening things together has always been a part of human knowledge ever since the early stages of civilization. For the purpose of fastening things, a number of materials have been used as vines, grass stalks, as well as strips of animal hide and leather thong. Rope probably developed from the thongs. A single thong was found too weak for some purposes, and so two or three thongs had to be combined. To twist the leather strips into a solid rope was a short and natural step.

In modern times, the use of ropes became universal. With the improvement in materials and methods came improvement in technique of making rope; and the two present methods, twisting and braiding, slowly evolved. In a twisted rope a few fibers are twisted to the right to form a yarn, then a few yarns are twisted to the left to form a strand. Three or four strands are twisted to the right to form a rope. Three ropes are twisted to the left to form a large cable-laid rope.

The important element in twisted rope is the alternation of directions so that the fibers and strands pull against each other and overcome their natural tendency to untwist and fray. The friction of the alternately twisted parts makes a hard compact rope, capable of repelling water and standing tremendous strains.

The braided type of rope is usually woven by a special braiding machine in much the same manner as are heavy fabrics. When made this way good cotton rope, such as "spotted cord," is smooth, compact, and capable of giving long service before it becomes too soft. Braided rope is used extensively for rope spinning.

# MAKING ROPE

You can make your own rope if you put together any of the machines shown here.

## ROPE CRANK

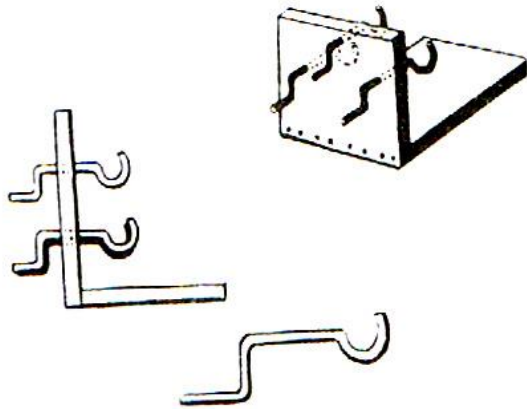

Use 3/4-inch wood for the parts. The hooks may be made of coat-hanger wire.

Use heavy binder or twine. Tie the end of the twine to one of the hooks and loop it back and forth between the hooks and the 6-inch dowel or pencil. About three strands to each hook will make a medium-sized rope. The "lay" needs to be three times the length of what you want the finished rope to be.

The number of strands will determine the size of the rope. Note the same number of strands must be placed on each hook so the finished rope will be laid evenly.

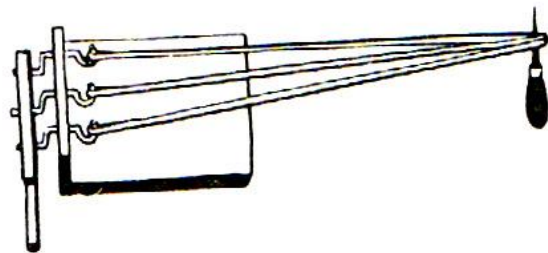

Insert the crank handle in the cranks and start rotating it. Hold the strands apart with the rope wrench until they get fairly tight. Then take hold of the strands behind the wrench - that is, on the side away from the machine - and begin twisting them slowly together as the wrench is moved forward.

The rope will go into shape itself and remain there, but the wrench should be used to ensure even twisting and to prevent kinks. The cranks should be turned slowly while the rope is being formed.

When your rope is complete, take it off the hooks and whip the ends to prevent fraying.

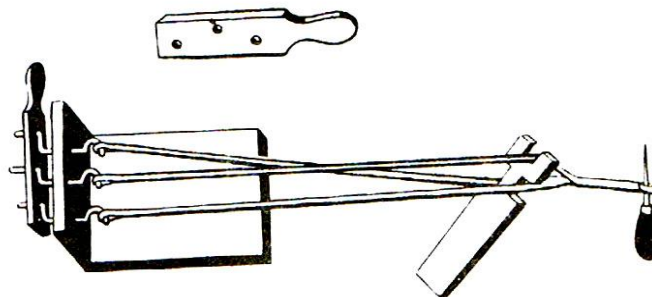

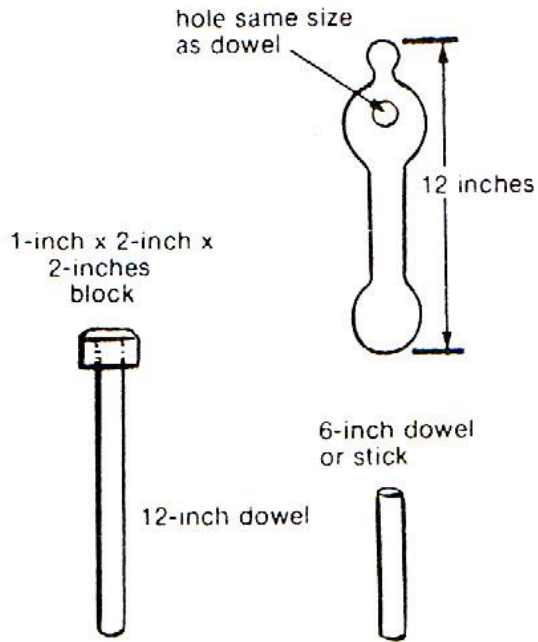

## ROPE SPINNER

Tie a loop on each end of a long piece of binder twine or heavy cord. Attach the twine to the spinner as shown in the diagram so that you have three strands. Spin the spinner in a clockwise direction. When the twine is wound tight take three of these strands and repeat. A third person should do this so that the line can be held stretched out, otherwise it will kink badly. Spin the spinner counter clockwise until rope is wound tight. Take rope off the spinner, whip the ends, and it's ready to use.



## SETTING A ROPE

If you are serious about using the rope you make, it should be strained to put the "set" in it. Take the rope off the machine and tie it between two strong points and put a strain on it.

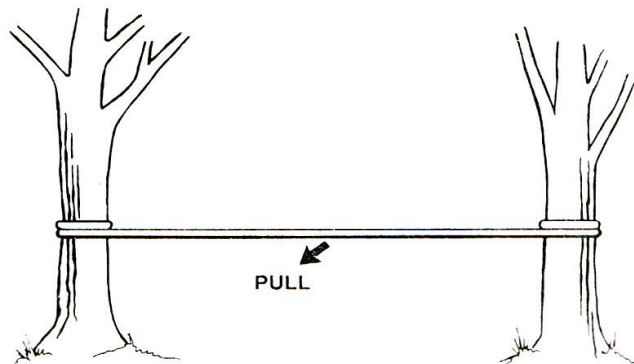

# WHIPPING

The ends of every rope should be whipped to keep them from raveling. There are several methods of doing this. For ropes of polypropylene and other synthetic fiber ropes, whipping may be done by applying a hot iron or flame to the ends. This fuses the strands. A rule of thumb is that the length of the whipping should be at least as long as the diameter of the rope.

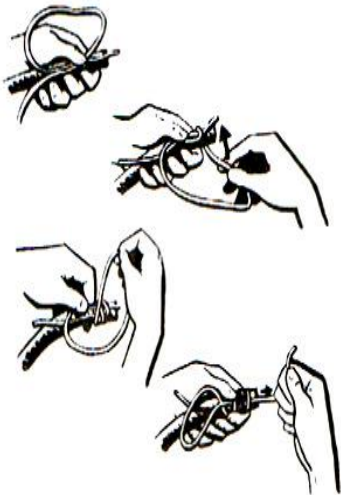

## AMERICAN WHIPPING

You can use any twine for American whipping, although waxed sail twine or electrician's twine is best. Begin by laying a loop of the twine on the end of the rope. Take several turns around the end of the rope, spiraling away from the end and drawing each turn tight. When the whipping is as wide as the diameter of the rope, pull on the end until the loop has disappeared.

## SAILMAKER'S WHIPPING

Begin by unlaying (untwisting) the rope 2 inches. Make a bight in a 3-foot length of twine and place it around one of the strands. Re-lay the rope. Wind the twine tightly around the rope end for a sufficient number of turns. Carry the bight originally formed back over the end of the same strand around which it was laid. Pull twine ends tight and tie them with square knot between the rope ends. Trim ends of twine.

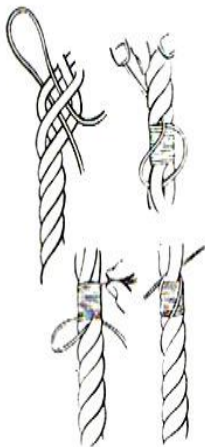

## ENGLISH WHIPPING

Make twine into a loop and place it at the end of the rope. Wrap the twine tightly around the rope. When whipping is as wide as the rope is thick, slip the end through the loop, pull hard, and trim off the twine.

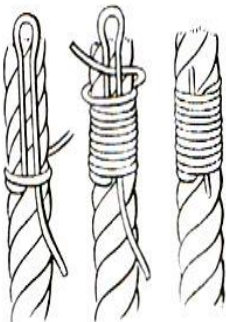

## CARING FOR ROPE

A good rope is expensive and should not be handled carelessly. Keep it clean and free of mud or grease. If it is damp, do not coil or store it until it is thoroughly dried out. Always keep it in a dry place. It should never be thrown into a corner to tangle and kink. When a job is finished, the rope should be placed where it will be available instantly, if necessary, and should be coiled so that it will pay out smoothly when needed.

## COILING ROPE

To coil rope, first shake it out in a straight line so there will be no kinks. Hold the end with one hand. With your other hand pull in enough rope to make a loop about 18 inches long. As you place the loop in your hand, roll the rope a half-turn with your thumb and forefinger. This will counteract the twist you put in the rope as you made the loop and will help to eliminate kinks.

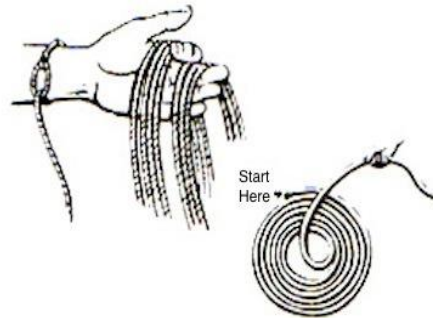

To make it a flat coil (as shown in the drawing), lay the outer circle first and coil in toward the center in a clockwise direction. Give a half-turn to each coil to eliminate kinks. If your coil is too loose, you can tighten it by twisting the center with the palm of your hand.

## BIGHT, LOOP, OVERHAND

Knots are formed by using the bight-loop-turn-tuck. Even the most complete knot can be figured out if you remember these terms.

The bight is formed by laying the end of the rope against the standing part or long end.

Loops, overhand or underhand, are just what their names say. With these three turns you can make any sort of knot.

A turn is wrapping the rope around something and a tuck is to insert the running end or a bight into a loop.

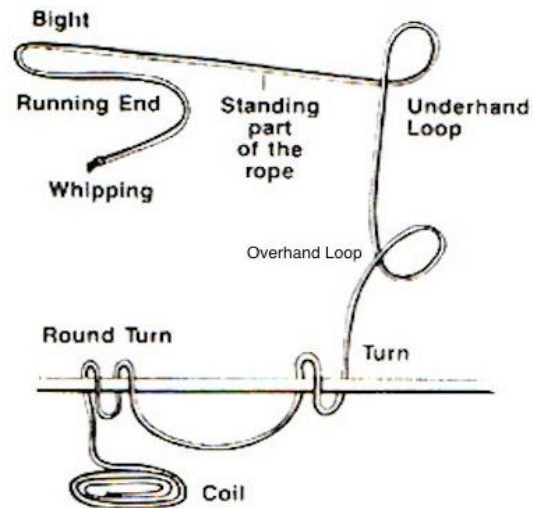

## HANSON KNOT

Tie an overhand knot in the standing part of the rope by making an overhand loop and pulling the end through the loop.

Bring the end back through the loose overhand knot as though you were making a slip knot.

Now, bring the end over the standing part, under it, and through the overhand knot. Make a half hitch by bending the end across the overhand knot and under itself so that it lies next to the standing part.

Tighten the overhand knot first and then the half hitch. To untie, push on the top loop (A) and pull on the bottom loop (B).

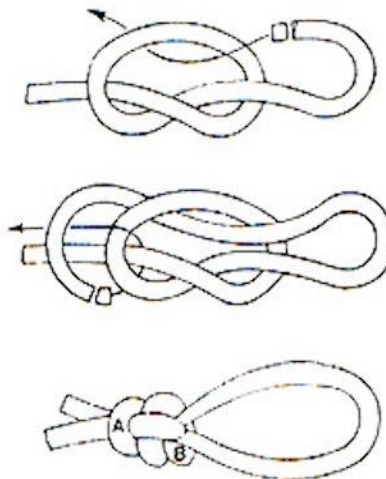

## HANSON KNOT (Variation)

Tie a figure 8 knot exactly like this one with the overhand loop over the standing part.

Roll the overhand loop on top of the underhand loop.

Pass the working end under the first two loops and over the last two as shown by the arrow.

Following the arrow, reach inside the loop just formed and pull the overhand loop while holding the running end against the underhand loop (x). The overhand not will tighten. Then pull the working end to jam the knot.

To untie, push on the part marked (A) and pull on the part marked (B).

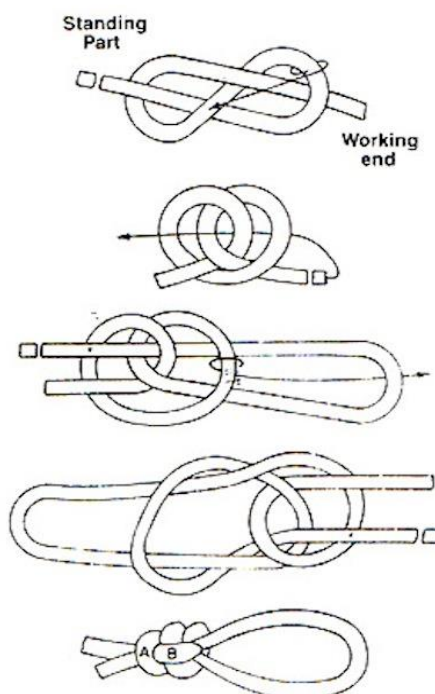



## END KNOTS

Knots in this group are most often used to prevent slipping. They may be tied in either the end or standing part of the rope to check it from sliding through a block, hole, or part of another knot. They may be used temporarily to stop fraying when a rope is not whipped.

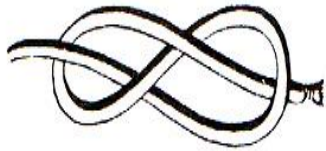

### FIGURE EIGHT KNOT

Often used in such places as the end of a string when tying a package with a slipknot or in the end of a rope forming a lariat loop.

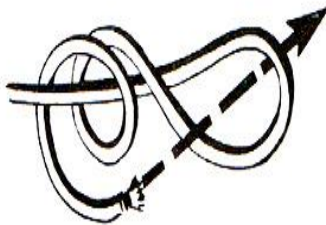

### STEVEDORE'S KNOT

This is the same as the figure eight, except that it has an extra loop that gives it more bulk at the end of the rope if that is required.



### WALL KNOT

This knot is a firm, round, semi-permanent "stopper" knot tied with the end strands of a rope. Snug it carefully so that strands tighten evenly. You can trim the end or twist them together again and whip the end.

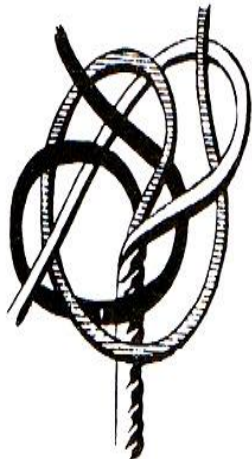

### SINGLE MATTHEW WALKER KNOT

Begin by tying the wall knot, but before snugging, carry each end through the bight ahead of it so that each strand runs under two bights.

## KNOTS FOR JOINING

These knots are used for tying two rope ends together: sometimes the ends of the same rope; sometimes the ends of different ropes.

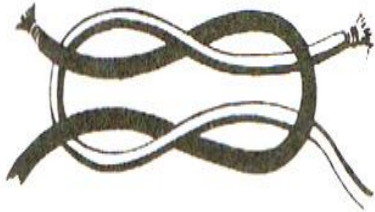

### SQUARE KNOT

You can loosen the square knot easily by either pushing the ends toward the knot or by "upsetting" the knot by pulling back on one and pulling the other through the loops.

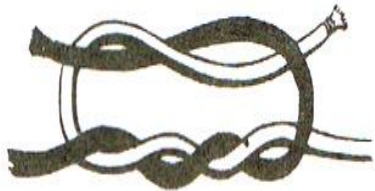

### SURGEON'S KNOT

The surgeon's knot is a square knot with an extra twist. The purpose of the extra twist is to give added friction to hold until the second crossing is made.

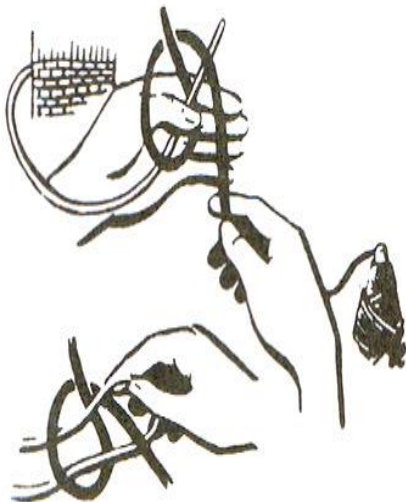

### WEAVER'S KNOT

The weaver's knot is exactly the same knot as the sheet bend, but tied in a different manner.

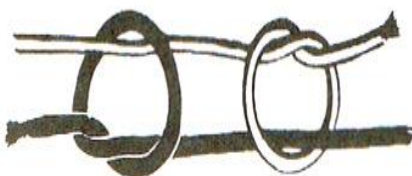

### FISHERMAN'S KNOT

The fisherman's knot is used for joining two fine lines such as fishing leaders. It is simply two overhand knots. one holding the right-hand line and the other the left-hand line. Pull each of the two overhand knots taut separately. Then make the whole knot taut so that the two overhand knots come together by pulling on the standing parts of each line.



### **SHEET BEND**

The sheet bend is an important knot for joining two rope ends, especially if the ropes are of different sizes. Sailors named it in the days of sailing ships when they would “bend” (tie) the “sheets” (ropes in the rigging of a ship).



Begin with a bight in the larger rope. Then weave the end of the smaller rope up through the eye, around the bight, and back under itself. Snug it carefully before applying any strain to the knot.

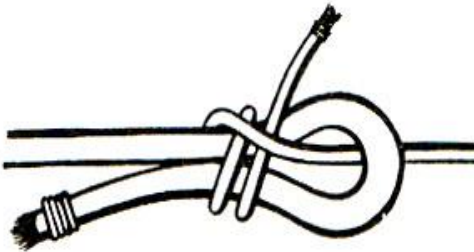

### **DOUBLE SHEET BEND**

When the two ropes being tied together vary widely in diameter the double sheet bend should be used. The two loops help to hold the bight in the larger rope. Consider using this also when the rope is wet or when using some of the slicker synthetic fiber ropes.



### **SLIPPERY SHEET BEND**

The slippery sheet bend is simply an ordinary sheet bend with a bight left in the smaller rope. This bight makes it “slipper” because it can be untied quickly, merely by a tug on the tree end of the rope. It is a valuable knot for use when you expect to tie an: untie it often.



### **SINGLE CARRICK BEND**

The carrick bend is among the strongest of knots, but requires that both ends be seized onto the standing parts. To make the carrick bend, begin by making a bight in the left-hand rope, then weave the right-hand rope through it as shown. Finish by seizing the ends of both ropes.

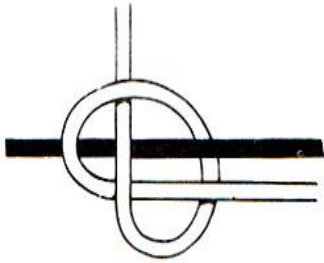

### **THE HUNTER'S BEND**

Only three new knots have been discovered during this century: the Constrictor knot many years ago, the Tarbuck knot discovered by Kenneth Tarbuck in 1958, and now Hunter's bend discovered by Dr. Edward Hunter.

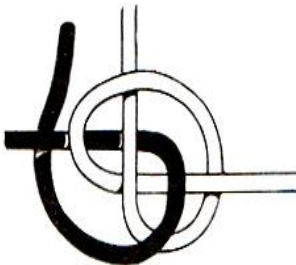

Hunter's bend is used to join two ropes. It has a distinct shape, does not distort, and is very easily untied. It is an excellent knot for nylon rope. Nylon ropes need something extra in knots for safety, and the double lock of Hunter's bend makes it ideal for this.

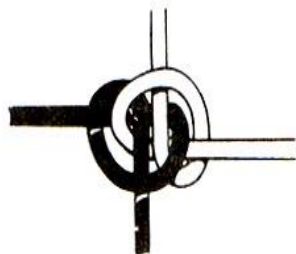

## TYING ROPES TO OBJECTS

Knots that are used for attaching ropes to things like poles or rings are called hitches. They are important in camping and all types of pioneering work.

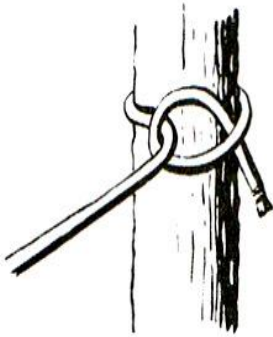

### HALF HITCH

The half hitch is the start of a number of other hitches and is useful all by itself as a temporary attaching knot. It will hold against a steady pull on the standing part, especially if a Stopper knot like the stevedore's knot or figure eight is put in the end.

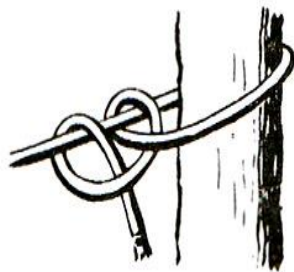

### TWO HALF HITCHES

This is a reliable and useful knot for attaching a rope to a pole or boat mooring. As its name suggests, it is two half hitches, one after the other. To finish, push them together and snug them by pulling on the standing part.

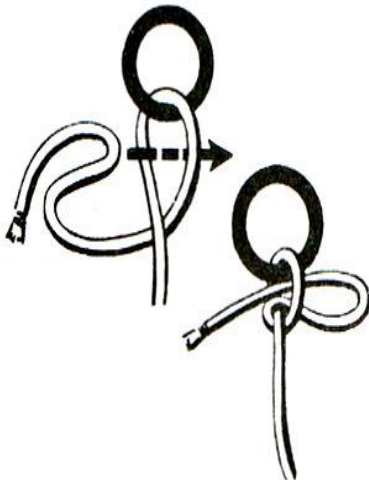

### SLIPPERY HALF HITCH

This is occasionally useful but should be considered temporary. It is actually only an overhand knot around the object with the end run back through the knot and left "slippery." It can be quickly untied by pulling on the free end. The slippery half hitch can be locked by passing the end back through the eye and pulling tight.

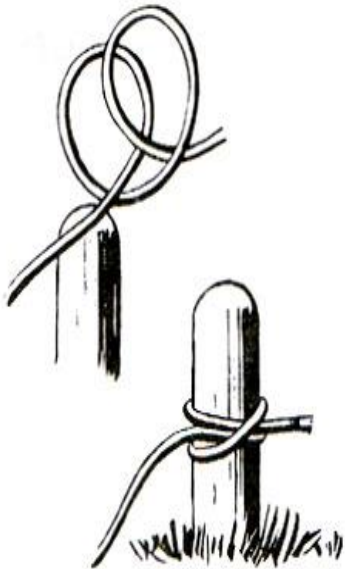

## CLOVE HITCH

This is one of the most widely used knots. Because it passes around an object in only one direction, it puts very little strain on the rope fibers. Tying it over an object that is open at one end is done by dropping one overhand and one underhand loop over the post and drawing them together.

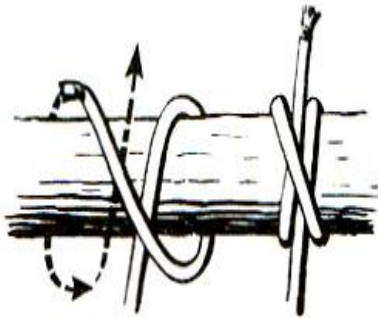

## CLOVE HITCH OVER BAR

This is the same knot as the clove hitch, but this method of tying it must be used if the bar is closed at both ends or it's too high to toss loops over. This hitch is used in starting and finishing most lashings.



## TIMBER HITCH

This is an important hitch, especially for dragging a heavy object like a log. It will hold firmly so long as there is a steady pull; slacking and jerking may loosen it. The timber hitch is also useful in pioneering when two timbers are "sprung" together.

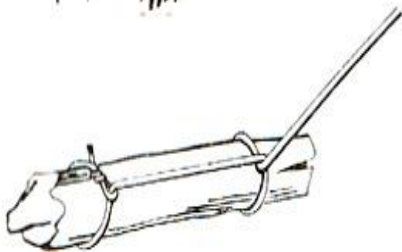

When it is used for dragging, a simple hitch should be added near the front end of the object to guide it.

## RUNGS

Two kinds of hitches which you can use in keeping the rope tight and firm in lashing and in securing the wooden rungs of a rope ladder. Are (1) the Lever Hitch, otherwise known as the Marline-Spike Hitch, and (2) the Magnus Hitch.

Study carefully the illustrated steps in trying these hitches and master them.

Note that the Magnus Hitch is similar to the Rolling Hitch or Stopper Hitch which is used to secure small line to a larger line when the strain is parallel or nearly parallel to the axis of the larger line.

Rolling Hitch becomes a Magnus Hitch when used to secured a line to a spar or a post and bears a strain either parallel or perpendicular to the spar.

Unlike in the Rolling Hitch, the second turn in the Magnus Hitch is not usually jammed inside the first turn and the end is usually tied to the standing parts or secured with two half hitches. This kind of knot resembles the clove hitch and is sometimes called the Mooring Hitch. These two hitches have advantages over each other in their uses.

The Lever or Marline-Spike Hitch is better used in tightening the wrapping and/or trapping of a lashing because it can be instantly tied and instantly released.

The Magnus Hitch on the other hand is better used for securing the wooden rungs of a rope ladder because it can better secure the rungs tightly and firmly.

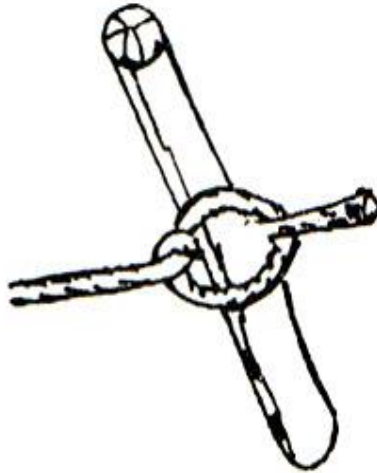

Lever Hitch

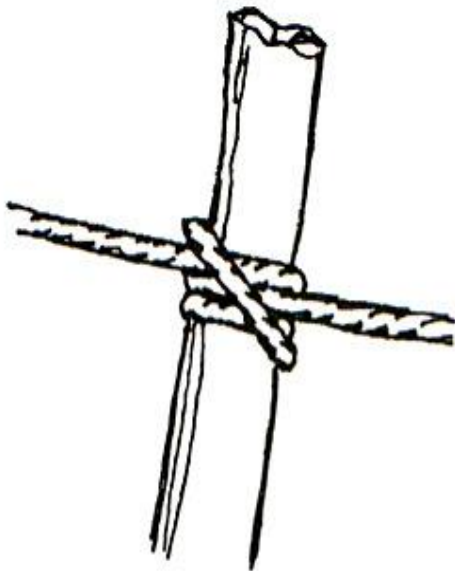

Magnus Hitch

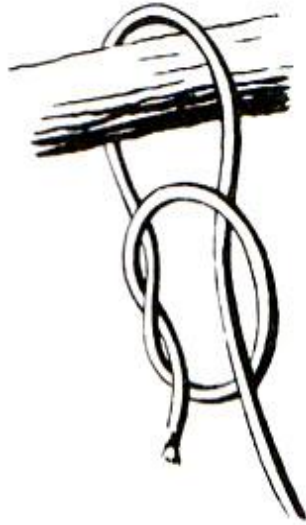

### **SLIPKNOT**

This knot is not as satisfactory as two half hitches because, unless strain is put on it, it may slide, especially on a vertical object like a post. Basically, it is an overhand knot around the standing part.

It will be more secure if a stopper knot, like a simple overhand or figure eight, is tied in the end of the rope.

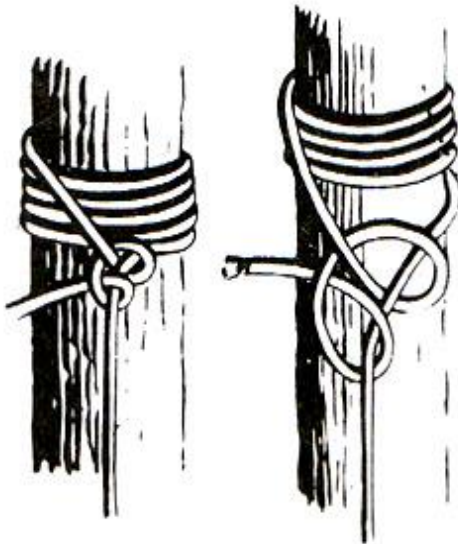

### **PIPE HITCH**

The pipe hitch is useful for lifting a bar or post straight up, as in pulling it out of the ground. To tie it, take four or five turns around the post. Cross the end over and finish with two half hitches around the standing part. An added hitch is usually taken higher on the post with the standing part to keep the post vertical.

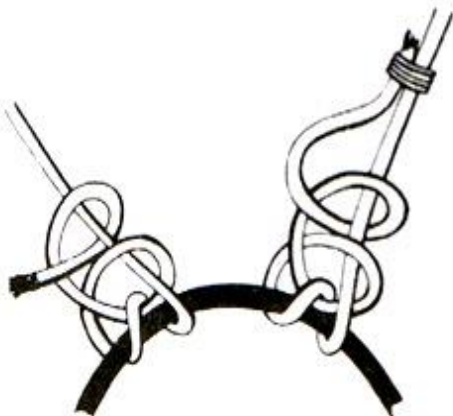

### **ANCHOR BEND**

This hitch, which is also called the fisherman's bend, is one of the strongest hitches. Begin by taking two turns around the post or ring. Then bring the end over the standing part and through the loop. Finish as in two half hitches. This can be made more secure by seizing the ends of the rope.



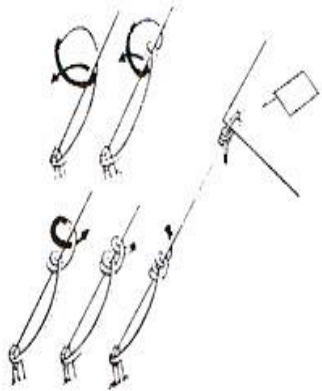

## TAUT-LINE HITCH

Can be tied on a line that is taut. When used for tying a tent guy line, you can tighten or loosen the line by pushing the hitch up or down on the standing part.

Pass rope around the peg. Then bring the end under and over the standing part and twice through the loop formed. Again, bring the rope end under, over, and through the loop formed. Tighten hitch around the standing part.

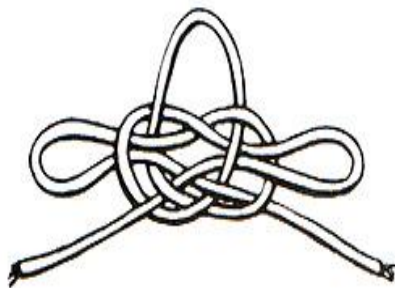
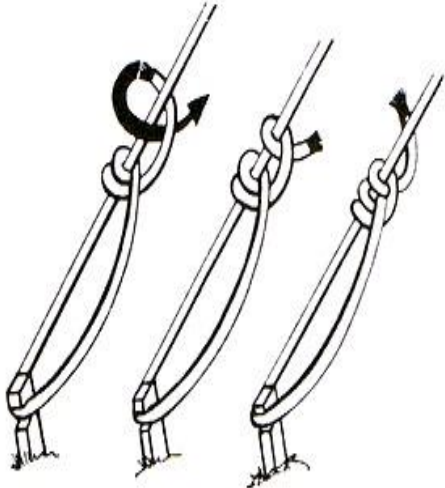

## MASTHEAD KNOT

The masthead knot is used principally for decorative purposes today. Originally, its purpose was to place a strap around a temporary masthead to which other straps could be made fast. This knot is started with three overlapping hitches. The inner bights of the two outer hitches are led in regular sequence over and under to the opposite sides of the knot, while the upper bight of the center hitch is merely extended.

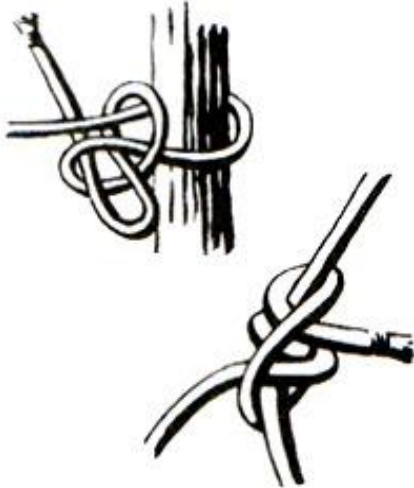

## HITCHING TIE

This is a common method of hitching animals. Notice that it is a type of slipped hitch.

## STOPPER HITCH

This is formed the same way as the taut-line hitch except that turns 1 and 2 are reversed.

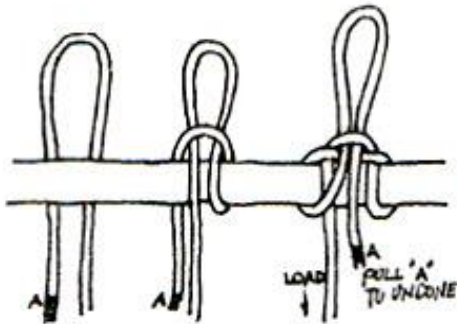

## DRAW HITCH OR HIGHWAY-MAN'S HITCH

This is a useful knot when going down and you want to use the rope again. Simply pull the loose side and you will retrieve the rope. Be careful enough to check first the knot by pulling the load side before using it. Failure in tying this knot will result in accident.



## SINGLE BLACKWALL

This is a simple halt hitch over a hook. It will hold only when subjected to a constant strain. A stopper knot in the end will make it a little more secure, but human life should never be entrusted to it.

## DOUBLE BLACKWALL

This hitch is somewhat safer than the single blackwall, but it, too, should be considered temporary. For a stronger, more permanent tie over a hook, use the bowline.



### **CAT'S-PAW**

The cat's-paw is a better way to attach a rope to a hook than either of the blackwalls. It will not slip and needs no constant strain to hold. For two loops and turn them inward one or two complete turns. Hang these "eyes" over the hook or other subject.

## **KNOTS FOR LOOPS**

These knots are used to hold loops - either permanent or "running" like a cowboy's lariat. The bowline and its variations are important for rescue work and on board ship where they have scores of uses.

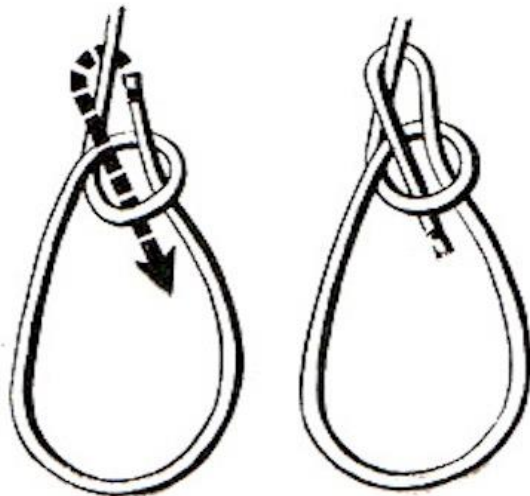

### **BOWLINE**

The bowline has been called the king of knots. It will never slip or jam if properly made and, thus, is excellent for tying around a person in a rescue. Begin by forming an over-hand loop in the standing part. Then take the free end up through the eye, around the standing part and back where it came from.



## FRENCH BOWLINE

This is a double bowline because it provides two nonslip loops (which can be of different sizes). With it a person can sit in one loop and have the second loop as a back support, leaving his hands free. It is excellent for rescue work or for seamen working over the side of a ship. Begin by making an overhand loop as in the regular bowline. But then pass the end through the "eye" twice before bringing it back around the standing part and through the original eye. The bottom drawing shows details of the final knot.

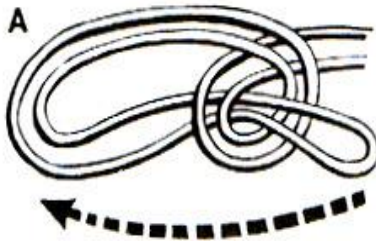

## BOWLINE ON A BIGHT

Like the French bowline, the bowline on a bight forms two loops, but they may be of the same size or differ. Start by making a good-size bight and an overhand loop as shown in figure A, and bring the end up through the loop. Open the end loop and bring it down and around the entire knot as in figure B. Set the knot securely before putting weight on it as in figure C.

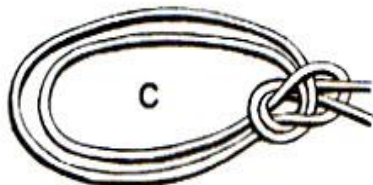
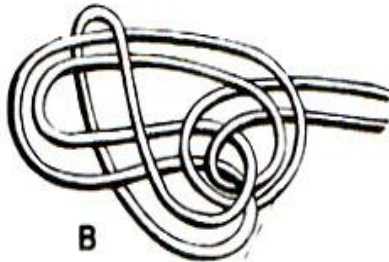

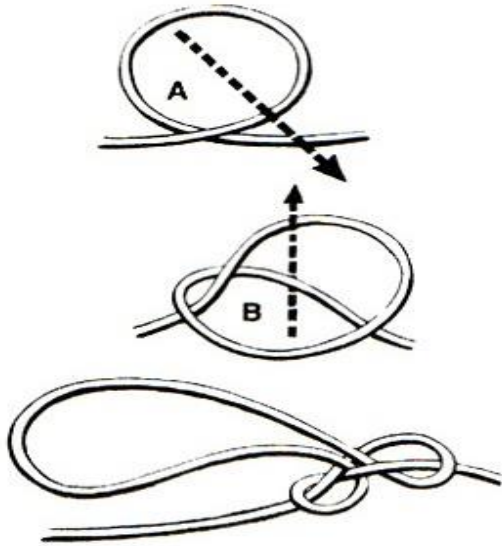

## MAN-HARNESS KNOT

The principal use of this knot is to make a loop in the middle of a rope that is being used for hauling or climbing. A man can then use the loop as a harness over his shoulder so he can put his full weight to its best use. Form an underhand loop as shown at top. Grasp the loop at A and lay it over the part of rope shown by the arrow. The result will be as shown in the middle drawing. Now grasp the rope at B and draw it up under and over as shown at bottom. This forms the bight which becomes the loop for your shoulder. Draw the knot tight before using it.

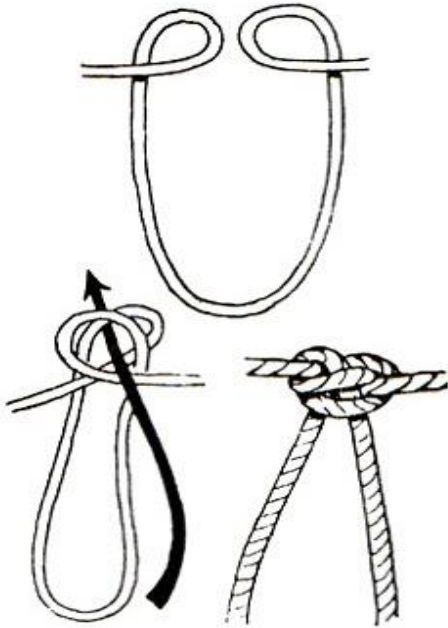

## ALPINE BUTTERFLY

This is the best knot for making a nonslip loop in the bight of a rope. Simply make a bight of the required size with two small overhand loops turned inward at the top. Overlap the loops and bring the bight up and through from front to back. Adjust as necessary.



### FIGURE EIGHT ON A BIGHT

Much used by mountain climbers, it makes a nonslip loop in any pan of the rope. It can be tied quickly and easily in difficult situations. This can be another loop end knot that can be used to form a running loop.

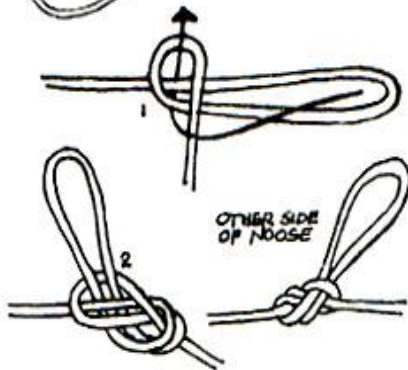

### ROVER NOOSE

The same use as a man harness knot.

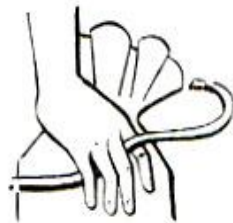

### OTHER USEFUL KNOTS

#### MILLER'S KNOT

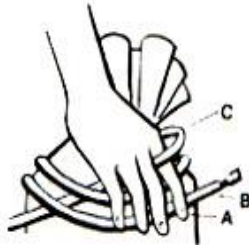

This is a close relative of the clove hitch and is used in tying sacks with heavy string or cord. Note that the first turn around the sack leads over the forefinger and the others pass under all fingers. In the middle drawing, the forefinger A is about to draw the cord end B under C to complete the knot. The final result is shown in the third drawing.





### **STRANGLE KNOT**

The strangle knot has many applications. For example, it may be used as an emergency whipping, or in place of the miller's knot. In the strangle knot, the important point is to cross the second turn over the first and to pull the end under both turns.

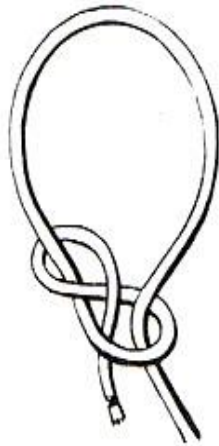

### **PACKER'S KNOT**

The packer's knot is one of the best ways to begin to wrap a package. It is simply a figure eight knot tied around the standing part. In wrapping packages or bundles, make the first turn by passing the loop of the packer's knot around the package and pulling it tight.

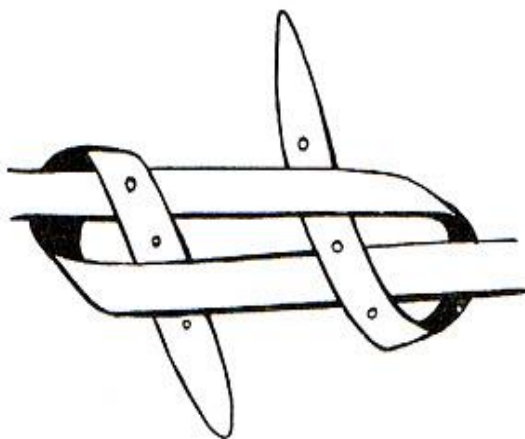

### **STRAP KNOT**

This knot is designed, especially, for tying flat leather straps. It is merely two interlocked loops. They should be pushed together. With a strap knot, leather belts or straps can be linked together to form an emergency rope.

**SHEEPSHANK**

This knot is used to shorten a rope that is fastened at both ends. Take up the slack as shown in figure 1. Make an underhand loop as shown at Bin figure 2 and slide it over the B1 bight and pull tight. Do the same to the other end to complete the knot. The sheepshank is only a temporary knot as it stands. But it can be made more permanent by adding a second halt hitch to each end as shown in figure 3.

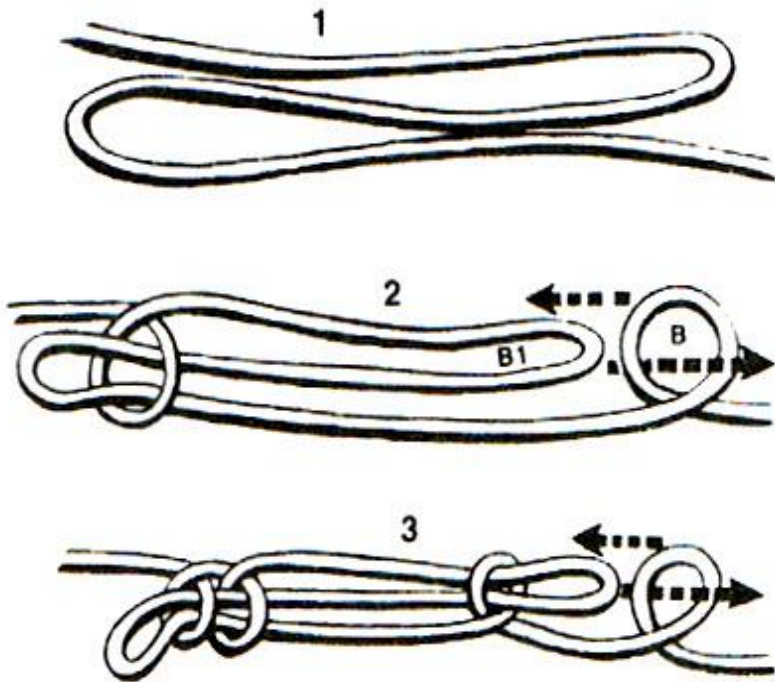

**TOGGLES**

A toggle is a small piece of wood or metal often used to lock a knot that may have to be loosened quickly or to help it hold better. Two examples are shown. At left is one end of a sheepshank with a toggle inserted to make sure the knot does not slip. At right is a lark's-head with toggle. Removing the toggle releases the hitch.

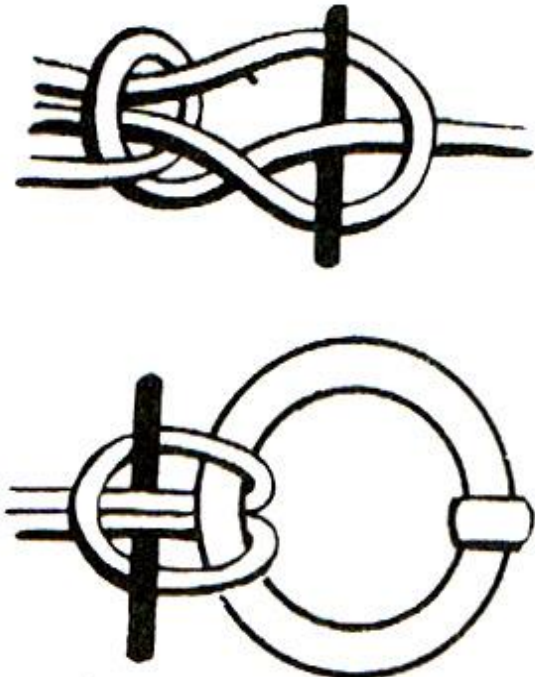



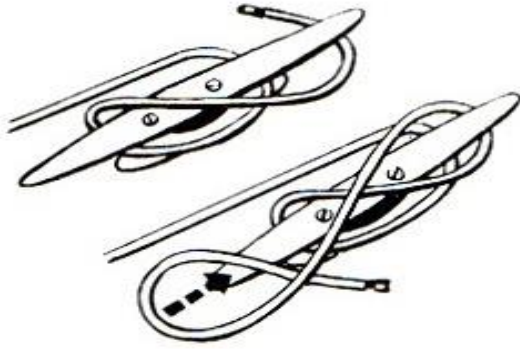

## BELAYING

This is a sailor's term for attaching a rope to a cleat. Begin with a turn as shown in the drawing. Then make one or two figure eight movements as in the second drawing. Finish with a hitch (underhand loop) pulled snug, unless the rope needs to be loosened quickly.



## MOORING HITCH

This is a good knot to moor a boat because it can be released quickly. It also holds fast. It is difficult to tie under tension. The mooring hitch is a slippery knot that gives a secure hitch.

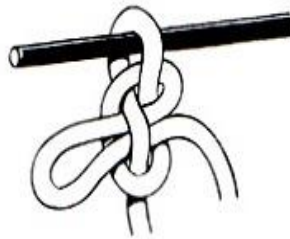

## DIAMOND HITCH

The diamond hitch, long used by prospectors, traders, and trappers in loading packhorses, is also a handy way to lash your pack to a six-point frame. Its advantage is that a pull on any section of the line makes every other section tighter. Begin by tying one rope end at point 1, using a clove hitch. Loop the rope over points 2 and 3 as shown in A. Before pulling the line through the bight between points 1 and 2, twist the other center strands two or three times as shown. Then loop the rope over the other points in numerical order as shown. When the hitch is nearly complete, pull the rope to tighten all sides and tie it at point 1 (over the starting hitch) with a hitch or knot. Drawing D shows the diamond hitch completed around a pack. Note the "diamond" in the center.

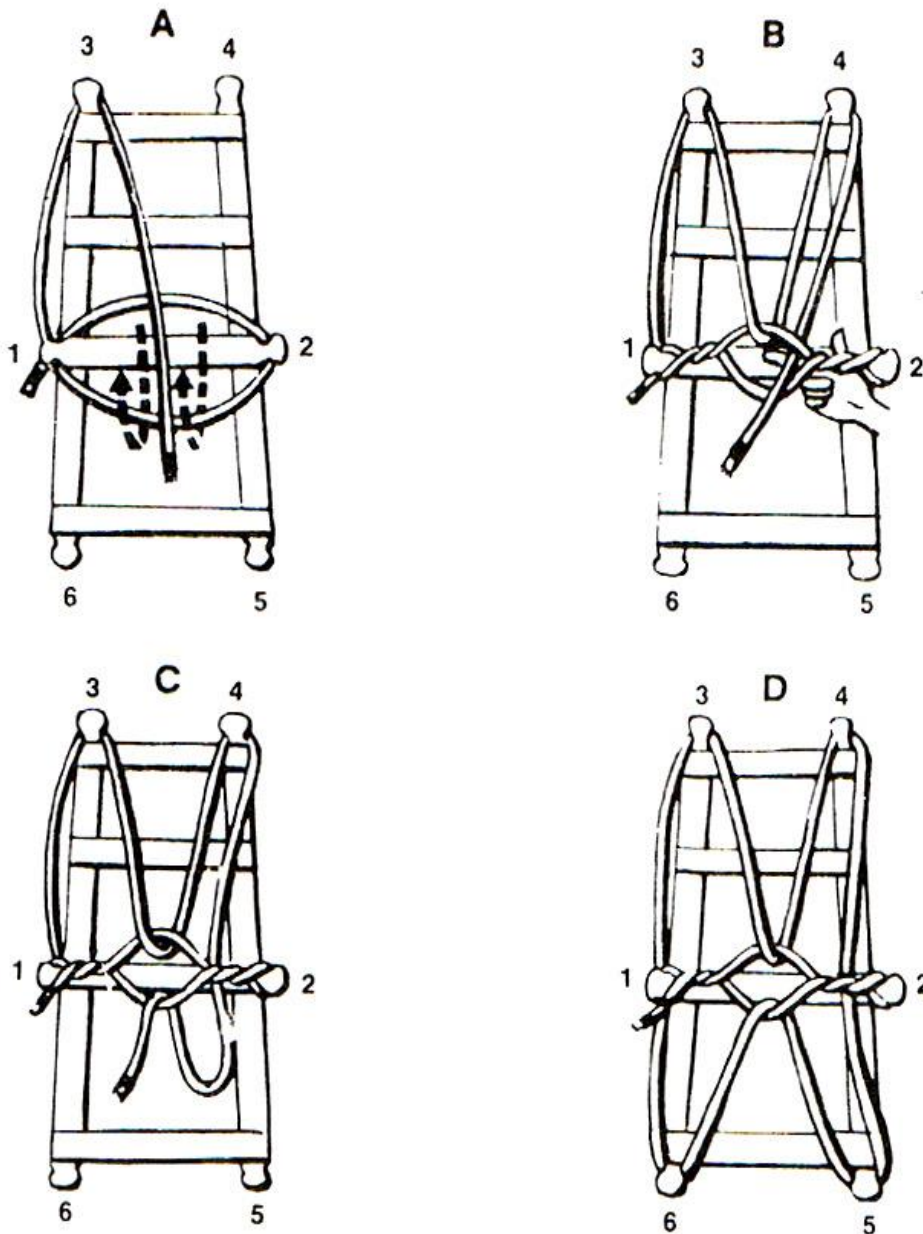

# SPLICES

Splices join ropes permanently and leave the rope almost as strong as it was originally. The strongest of them is the short splice. It makes a small bump in the rope, however, so it will not pass over a block. The long splice is a little less strong, but with it the rope remains the same diameter. The eye splice and back splice have special purposes.

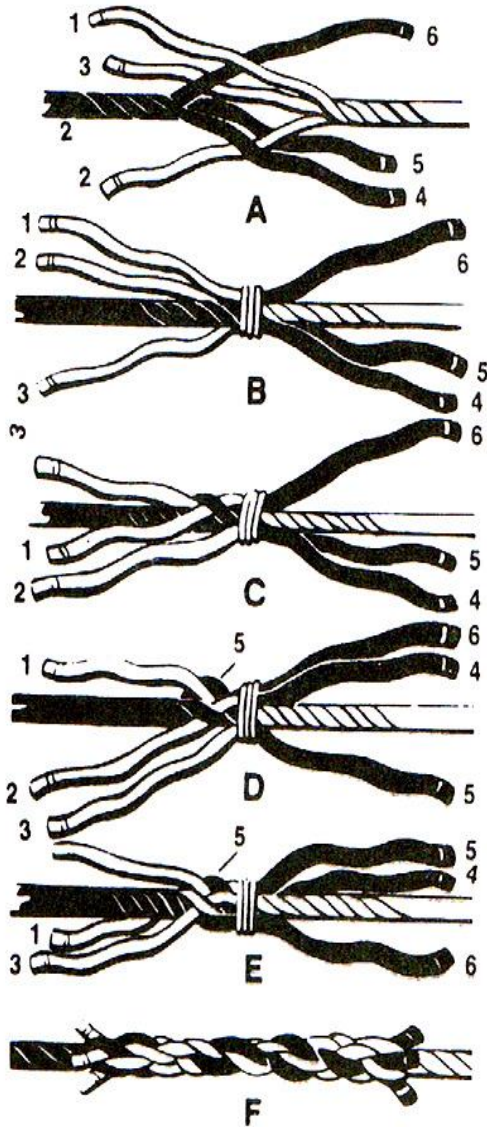

## SHORT SPLICE

Begin by unlaying (untwisting) the ropes a few turns. If the rope is large, make temporary whippings on the ends of the strands.

- A) Alternate the strands of the two ropes.
- B) Tie strands down to prevent more unlaying.
- C) Tuck strand 1 over an opposing strand and under the next strand.
- D) Tuck strand 2 over strand 5, under the second, and out between the second and third.
- E) Repeat operation with strands 1 and 3 from same rope end.
- F) Remove tie and repeat operation on other rope end. Make two or more tucks for each strand. Then roll the tucks and cut off ends. You can smooth the splice by rolling it under your foot on the floor.

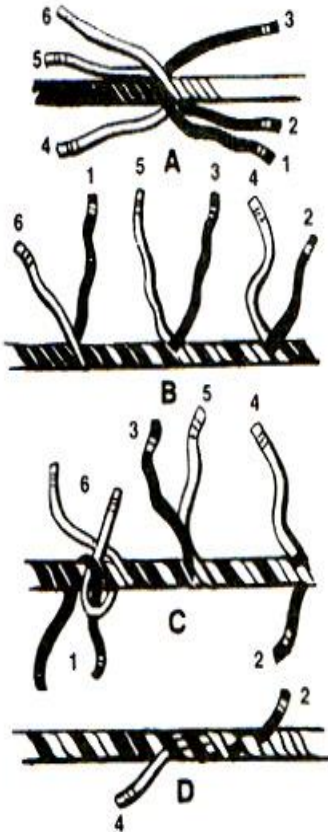

## LONG SPLICE

- A) Unlay each rope end about 15 turns. Place the two rope ends together, alternating strands of each end.
- B) Using opposite pairs, unlay one end 4 and fill its place with the "partner" strand 2. Repeat operation exactly with another pair of strands 1 and 6 in opposite direction.
- C) Trim the longer strand 4 and tie each pair of opposing strands 2 and 4 with an overhand knot, tucking each strand twice. The tuck goes over one strand, under the second, and out between the second and third. Strands 3 and 5 are simply tied with an overhand knot. Strands 1 and 6 are halved, and opposite strands tied with an overhand before tucking.
- D) Roll and pound all tucks into the rope and then clip the individual strand ends.

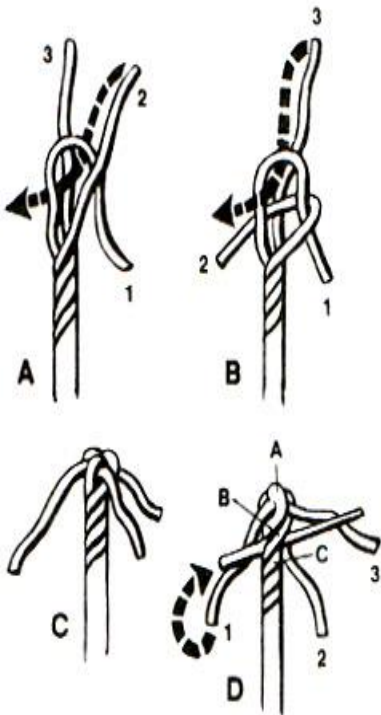

## BACKSPlice

The backsplice is a method of preventing fraying or raveling in the end of a rope. It is more durable and permanent than whipping.

Begin by unlaying the rope and making a crown knot as shown in drawings A, B, C. The ends are then tucked with the over-and-under movement. See drawing D.

Finish by trimming the ends and smoothing the splice by rolling it on the floor with your foot.

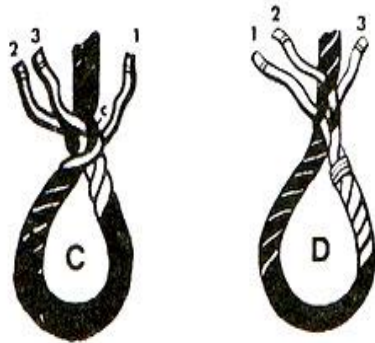
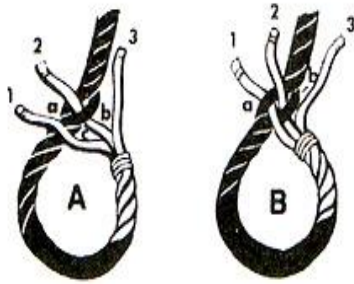

## EYE SPLICE

The eye splice is the strongest type of rope loop. Like the short splice, it is woven "one over, one under." Strands may be loosened for tucking by twisting the rope in the direction opposite the lay.

Begin by unlaying the end four or five turns.

- A) Tuck strand 2 over strand c, under b, and then out between strands a and b.
- B) Tuck strand 1 once over strand c and under a.
- C) Turn rope over and tuck strand 3 under strand c and over next strand.
- D) Tuck each strand in turn over and under for several tucks.

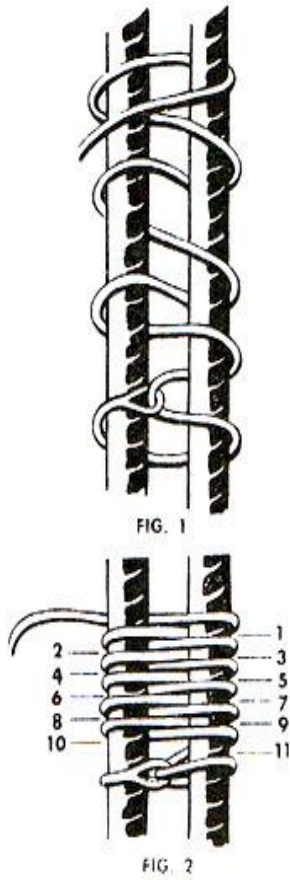

## RACKING SEIZING

Racking seizing is used to lash together two parallel ropes. Start with a timber hitch "in the seizing material and then wrap it around the ropes in a figure eight pattern as shown in figure 1. Make as many turns as necessary. When this is done, bring the turns together as shown in figure 2. Now begin winding round and round back toward the eye splice, laying the lashing into the spaces between the turns of the first set as indicated by the numbers in figure 2. The seizing may be finished by making frapping turns and fastening with a clove hitch.

# LASHINGS

For lashing or binding together timbers with rope, it's important to use ropes of correct thickness and length. For staves or spars up to 1-1/4 inches in diameter, use tough twisted or braided line. For spars up to 3 inches in diameter, you need 1/4-inch rope. For spars over 3 inches in diameter use 3/8-inch rope. As to length, figure 1 yard of rope for each inch of the combined diameter of the spars. For example, when you are lashing 3-inch and 4-inch timbers together, you will need 7 yards of rope.

Frapping turns are used to draw the lashing tight.



## SHEAR LASHING

The shear lashing is used for forming shear legs of timbers in pioneering bridges. Begin by laying the spars parallel to one another. Tie a clove hitch around one spar. Then bind the two timbers together by laying seven or eight turns around them, loosely, one turn beside the other. Then make two frapping turns around the lashing between the spars. Fasten the rope end with a clove hitch around the second timber. Open out the two timbers to form shear legs.

Sometimes shear lashings are used to lash two spars together to keep them parallel (to extend a flagpole, for example). In that case, do not use trapping turns.

Sometimes, in this type of lashing it is necessary to put a long, tapered wedge behind the lashing to tighten it.





## DIAGONAL LASHING

A diagonal lashing is used to "spring" two spars together; that is, to lash together two spars that do not touch where they cross. Begin with a timber hitch around both spars. Tighten it to draw the two close together. Three or four turns are then taken around one fork; three or four more around the other. The turns should be beside each other, not on top of each other. Then take two trapping turns about the lashing at the point where the spars cross. Finish with a clove hitch around either spar.

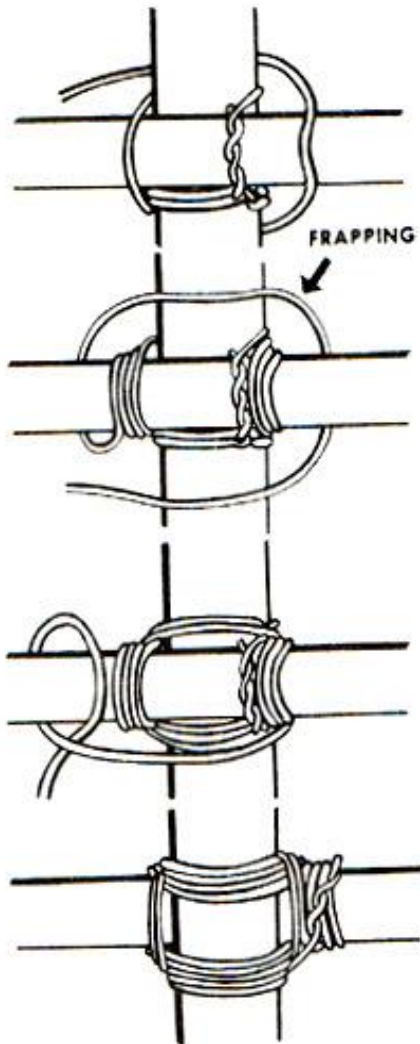

## SQUARE LASHING

A square lashing is used whenever spars cross at an angle, touching each other where they cross. Start with a clove hitch around the upright, directly below where the crosspiece will be. After tightening it, twist the free rope end and the standing part around each other to hold the loose end. Now wrap the rope behind the upright, down in front of the crosspiece, and around behind the upright. Do this three times, keeping outside the previous turns on the crosspiece and inside them on the upright. Then make two trapping turns between the timbers and strain them tightly. The lashing is then finished with a clove hitch on the crosspiece. Make all turns as tight and secure as possible.

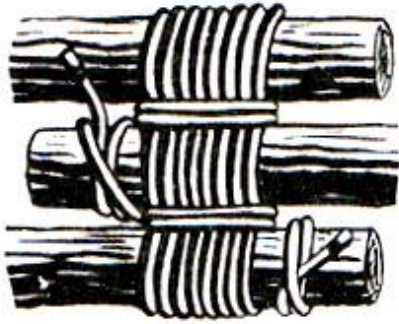

## TRIPOD LASHING

The method for forming a tripod is similar to shear lashing. Begin by laying the three spars on the ground pointing in alternate directions. Make a clove hitch or timber hitch around one of the outside spars. Now take seven or eight loose lashing turns around all three spars and two trapping turns in the spaces between. Finish with a clove hitch on the center spar and hoist the tripod into place.

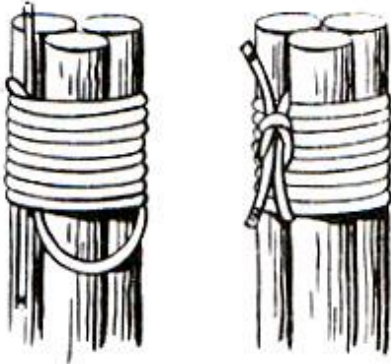

## TRIPOD LASHING FOR LIGHT STRUCTURES

Hold spars as in drawing. Place rope end in groove between spars. Wrap lightly a few times around spars and bring rope end up in groove. Finish with square knot and open tripod.

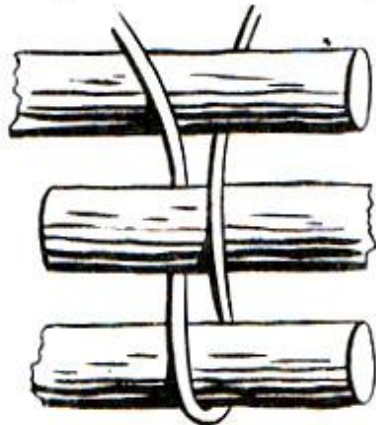

## TRIPOD LASHING FOR LARGE STRUCTURES

Lay the three spars on the ground pointing in alternate directions. Starting at the middle of the rope, weave around the spars a few times with each rope end. Tighten with two trapping turns in the spaces between spars. Finish with square knot and swing middle spar over.



It may take a little practice to judge how tight the wraps should be made and still allow for the tripod to set up.



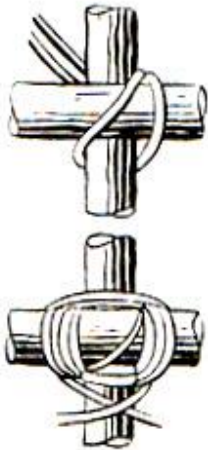

## JAPANESE SQUARE LASHING

Begin by using the rope doubled. Loop the bight around one spar and wrap just like the regular square lash with rope doubled. When trapping, split the ropes apart and trap in opposite direction with each. Finish with square knot.

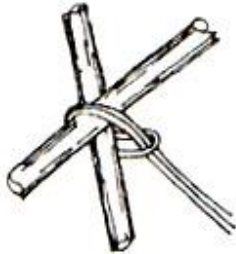

Start of Filipino Lashing



Filipino Lashing Completed

## FILIPINO LASHING

Begin by using the rope doubled. Loop the bight around the two spars and insert the running end into the bight and wrap around the two spars just like the regular diagonal lashing. Finish by splitting the two ropes and wrap around one spar in opposite direction and finish with square knot.

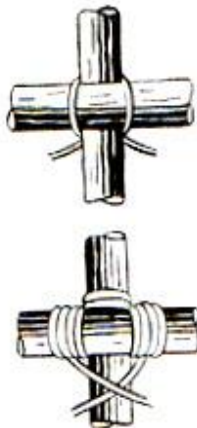

## JAPANESE SQUARE LASHING MARK II

Begin as with the Japanese lashing, but instead of using two ropes together, use each one separately and wrap in opposite directions. Frap using ropes in opposite directions and finish with a square knot.

# INDEX

Alpine Butterfly, 21  
American Whipping, 6  
Anchor Bend, 16  
Backsplice, 28  
Belaying, 25  
Bight, 7  
Bowline, 19  
Bowline on a Bight, 20  
Caring for Rope, 7  
Carrick Bend, Single, 12  
Cat's Paw, 9  
Clove Hitch, 14  
Clove Hitch Over Bar, 14  
Coiling Rope, 7  
Development of Rope, The, 5  
Diagonal Lashing, 31  
Diamond Hitch, 26  
Double Blackwall, 18  
Double Sheet Bend, 11  
Draw Hitch, 18  
End Knots, 9  
English Whipping, 6  
Eye Splice, 29  
Figure Eight Knot, 9  
Figure Eight on a Bight, 22  
Filipino Lashing, 33  
Fisherman's Knot, 10  
French Bowline, 20  
Half Hitch, 13  
Hanson Knot, 8  
Highwayman's Hitch, 18  
Hitching Tie, 18  
Hunter's Bend, The, 12  
Japanese Square Lashing, 33  
Japanese Square Lashing Mark II, 33  
Knots for Joining, 10  
Knots for Loops, 19  
Lashings, 30  
Long Splice, 28  
Loop, 7  
Making Rope, 6  
Man-Harness Knot, 21  
Masthead Knot, 17  
Miller's Knot, 22  
Mooring Hitch, 25  
Other Useful Knots, 22  
Overhead Knot, 7  
Packer's Knot, 23  
Pipe Hitch, 16  
Racking Seizing, 29  
Rope Crank, 4

Rope Spinner, 5  
Rover Noose, 22  
Rungs, 15  
Sailmaker's Whipping, 6  
Setting a Rope, 5  
Shear Lashing, 30  
Sheepshank, 24  
Sheet Bend, 11  
Short Splice, 27  
Single Backwall, 18  
Single Matthew Walker Knot, 9  
Slipknot, 16  
Slippery Half Hitch, 13  
Slippery Sheet Bend, 11  
Splices, 27  
Square Knot, 10  
Square Lashing, 31  
Stevedore's Knot, 9  
Stopper Hitch, 18  
Strangle Knot, 23  
Strap Knot, 23  
Surgeon's Knot, 10  
Taut-Line Hitch, 17  
Timber Hitch, 14  
Toggles, 24  
Tripod Lashing, 32  
Tripod Lashing for Large Structures, 32  
Tripod Lashing for Light Structures, 32  
Two Half Hitches, 13  
Tying Ropes to Objects, 13  
Wall Knot, 9  
Weaver's Knot, 10  
Whipping, 6

## **CREDITS**

KNOTS, BSA  
BSP BOOK VOL. 1 & 2  
FUN WITH ROPES & SPARS, John Thurman